

SC / SU Series

Standard Cylinder



We make the difference

- Cylinder
- Sizing
- SI
- SI A.
- SC / SU
- SCT
- SC A.
- SL
- SQ
- DNT
- SIB
- JDA
- CQ2
- CJ2
- CDU
- TN
- CXS
- MGP
- MSQ

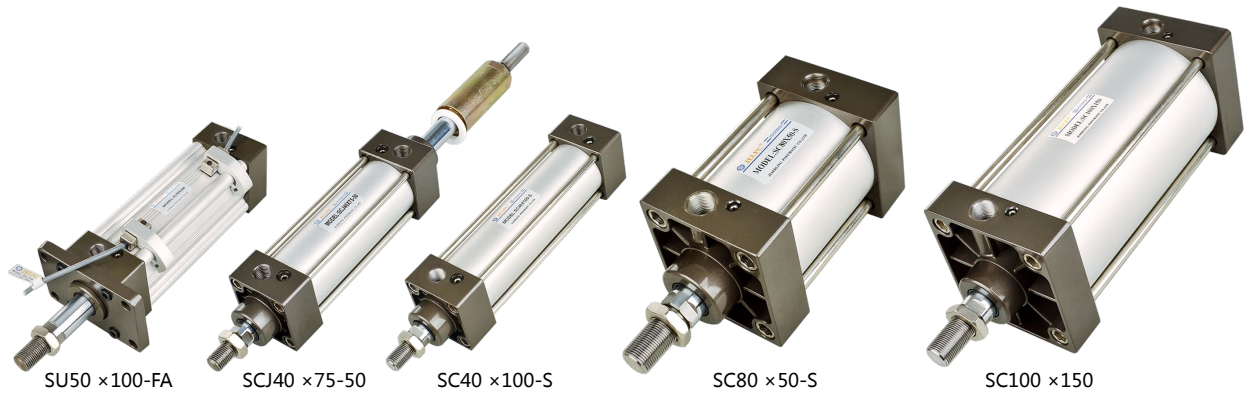

Ordering Code

SC	D	50	50	25	S	LB	MT
Series	Series Code	Bore	Stroke	Adjustable Stroke	Magnet	Mountings	Sensor
SC: Tie rod type 	Blank: Standard double acting 	32 40 50			S: With magnet Blank: Without magnet	Blank: Basic mounting LB: Foot 	JEL-21R Type
SU: Profile type 	D: Double-shaft double acting J: Double-shaft with adjustable stroke type 	63 80 100 125 160 200 250 320				FA: Front flange FB: Back flange CA: Back hinge CB: Back hinge TC-M: Center trunnion 	SC: Bracket for switch SU: Bracket for switch

* Standard wire is 1 meter, please order for other length

Specification

Bore (mm)	32	40	50	63	80	100	125	160	200	250	320	
Operation	Double Acting											
Working Medium	Air											
*Mountings	Basic FA FB CA CB LB TC TC-M											
Operating Pressure Range	1 ~ 9.0 Kg/cm ²											
Proof Pressure	13.5 Kg/cm ²											
Operating Temperature Range	0 ~ 70 °C											
Operating Speed Range	50 ~ 800 mm/s											
Cushion	Adjustable Cushion											
Adjustable Cushion Stroke	20 mm				26 mm				45 mm	52 mm	66 mm	
Port Size	G 1/8"	G 1/4"		G 3/8"			G 1/2"		G 3/4"		G 1"	

*SCD, SCJ mountings: FA, FB, LB, TC and TC-M type.

Stroke

Bore	Standard Stroke	Max. Stroke	Allowable Stroke
32	25 50 75 80 100 125 150 160 175 200 250 300 350 400 450 500	1000	2000
40	25 50 75 80 100 125 150 160 175 200 250 300 350 400 450 500 600 700 800	1200	2000
50	25 50 75 80 100 125 150 160 175 200 250 300 350 400 450 500 600 700 800 900 1000	1200	2000
63	25 50 75 80 100 125 150 160 175 200 250 300 350 400 450 500 600 700 800 900 1000	1500	2000
80	25 50 75 80 100 125 150 160 175 200 250 300 350 400 450 500 600 700 800 900 1000	1500	2000
100	25 50 75 80 100 125 150 160 175 200 250 300 350 400 450 500 600 700 800 900 1000	1500	2000
125	25 50 75 80 100 125 150 160 175 200 250 300 350 400 450 500 600 700 800 900 1000	1500	2000
160	25 50 75 80 100 125 150 160 175 200 250 300 350 400 450 500 600 700 800 900 1000	1500	2000
200	25 50 75 80 100 125 150 160 175 200 250 300 350 400 450 500 600 700 800 900 1000	1500	2000
250	25 50 75 80 100 125 150 160 175 200 250 300 350 400 450 500 600 700 800 900 1000	1500	2000
320	25 50 75 80 100 125 150 160 175 200 250 300 350 400 450 500 600 700 800 900 1000	1500	2000

Internal Structure

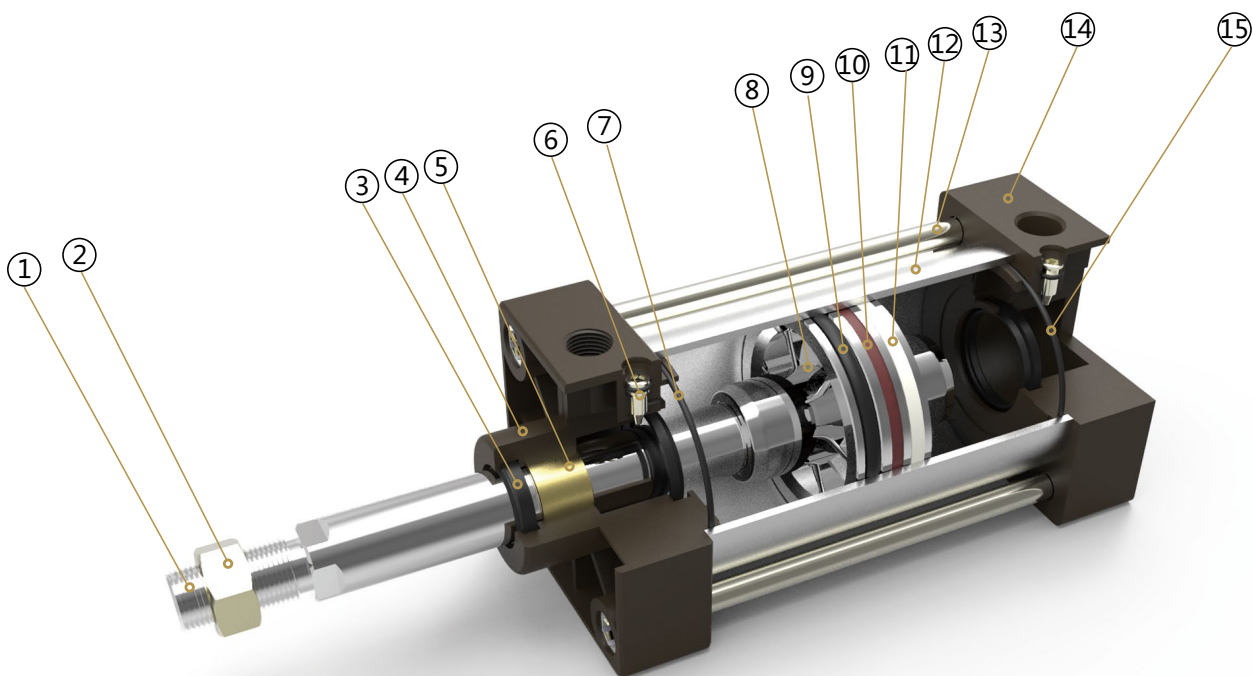

Parts

Number	Name	Number	Name
1	Piston rod	9	Piston seal
2	Hexagon nut	10	Magnet
3	Shaft seal	11	Anti-friction ring
4	Front cover	12	Barrel
5	Copper tube	13	Pull rod
6	Cushion adjust screw	14	Back cover
7	Cushion seal	15	O ring
8	Piston		

SC / SU Series

Standard Cylinder



We make the difference

- Cylinder
- Sizing
- SI
- SI A.
- SC / SU
- SCT
- SC A.
- SL
- SQ
- DNT
- SIB
- JDA
- CQ2
- CJ2
- CDU
- TN
- CXS
- MGP
- MSQ

Overall Dimension

SC

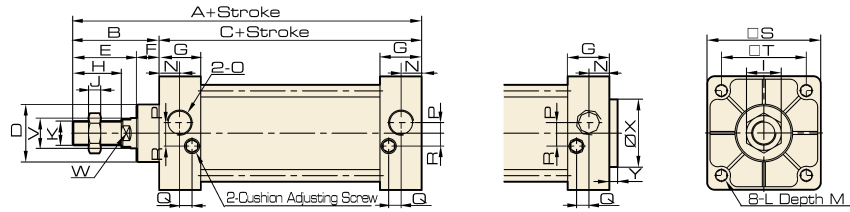

SCD

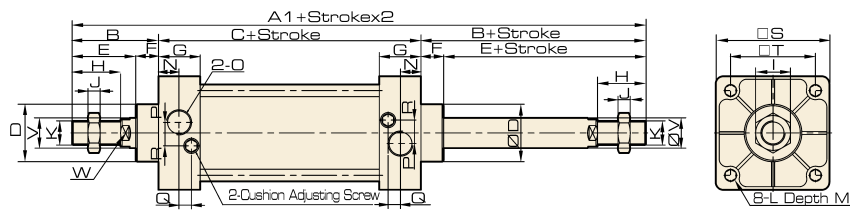

SCJ

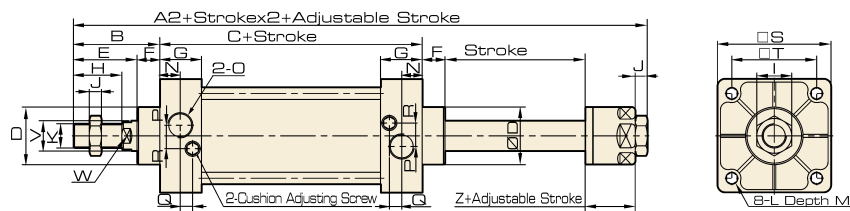

Dimension

Bore/ Symbol	A	A1	A2	B	C	D	E	F	G	H	I	J	K	L
32	140	187	182	47	93	28	32	15	27.5	22	17	6	M10 × 1.25	M6
40	142	191	185	48	93	32	34	15	27.5	24	17	7	M12 × 1.25	M6
50	150	207	196	57	93	38	42	15	27.5	32	23	8	M16 × 1.5	M6
63	153	210	199	57	96	38	42	15	27.5	32	23	8	M16 × 1.5	M8
80	183	258	243	75	108	47	54	21	33	40	26	10	M20 × 1.5	M10
100	189	264	249	75	114	47	54	21	33	40	26	10	M20 × 1.5	M10
125	226	/	/	104	122	55	70	34	33	54	40	10	M27 × 2	M12
160	291	/	/	123	168	62	93	30	50	72	55	18	M36 × 2	M16
200	347	/	/	167	180	80	112	55	50	72	55	18	M36 × 2	M16
250	389	/	/	189	200	90	122	67	54	84	65	21	M42 × 2	M20
320	436	/	/	216	220	110	126	90	65	96	75	24	M48 × 2	M24

Bore/ Symbol	M	N	O	P	Q	R	S	T	V	W	Z	X	Y
32	9.5	13.5	G 1/8	3.5	7.5	7	45	33	12	10	21	/	/
40	9.5	1.5	G 1/4	6	8.2	9	50	37	16	14	21	/	/
50	9.5	13.5	G 1/4	8.5	8.2	9	62	47	20	17	23	/	/
63	9.5	13.5	G 3/8	7	8.2	8.5	75	56	20	17	23	/	/
80	11.5	16.5	G 3/8	10	9.5	14	94	70	25	22	29	/	/
100	11.5	16.5	G 1/2	11	9.5	14	112	84	25	22	29	/	/
125	15.5	16.5	G 1/2	10	10	11	140	110	32	27	/	/	/
160	17.5	25	G 1/2	/	/	/	180	140	40	36	/	/	/
200	17.5	25	G 3/4	/	/	/	220	175	40	36	/	/	/
250	25	31	G 1	18.5	5	40	270	220	50	46	/	90	10
320	28	31	G 1	35	15	35	350	270	63	55	/	110	10