

DN Series

Stainless Steel Mini Cylinder

(ISO6432 Standard)



We make the difference

- NEW
- 5V100
- 5V200
- 5V300
- 5V400
- JSY
- JEL10
- JEL-JN
- 551
- 4F210
- JELVD
- DN**
- DSN
- DN/DSN A
- MA
- MAC
- MA/MAC A
- MAL
- MALC
- MAL/MALC A
- SDA

Features

1. Improving for adapting wide range applications, using precisepolishing of piston rod, more sense of products quality and longer life of front seal.
2. Optima design and improve the production efficiency.
3. Combined with enterprise color planning and new structure design, stainless steel series cylinder integrated as the semicircular groove cramping.
4. Using embedded gasket, increase the pressured area of pistons after collision.



DN25X75

Ordering Code

DN	U	32	x	50	25	S	E	LB	MT
Specification	Back Form	Bore	Stroke	Adjustable stroke	Magnet	Piston rod Material	Mountings	Sensor	
DN : Double Acting	Blank:Standard with eye mounting	8			S: With magnet	Blank : Carbon steel	Blank: Basic mountings	JEL-03R	
DS : Single acting, Spring-out	CM:Standard with round back cover	10			Blank: Without magnet	E : Stainless steel	LB: Front and back mounting		
DT : Single acting, Spring-in	U:Standard with flat back cover	12					FA: Front mounting flange		
DND : Double-shaft		16					FB: Back mounting flange		
DNJ : Double-shaft with adjustable stroke		20					SDB: Back hinge		
		25							
		32							
		40							

Specification

Bore(mm)	08	10	12	16	20	25	32	40
Operation	Double Acting or Single Acting							
Working Medium	Air							
Mountings	Basic LB FA FB SDB							
Operating Pressure	0.1 ~ 1.0Mpa							
Proof Pressure	1.5 Mpa							
Operating Temperature Range	-20 ~ 70°C							
Operating Speed Range	50 ~ 800mm/s							
Cushion	Gasket Cushion							
Port Size	M5x0.8				G1/8"			

Internal Structure

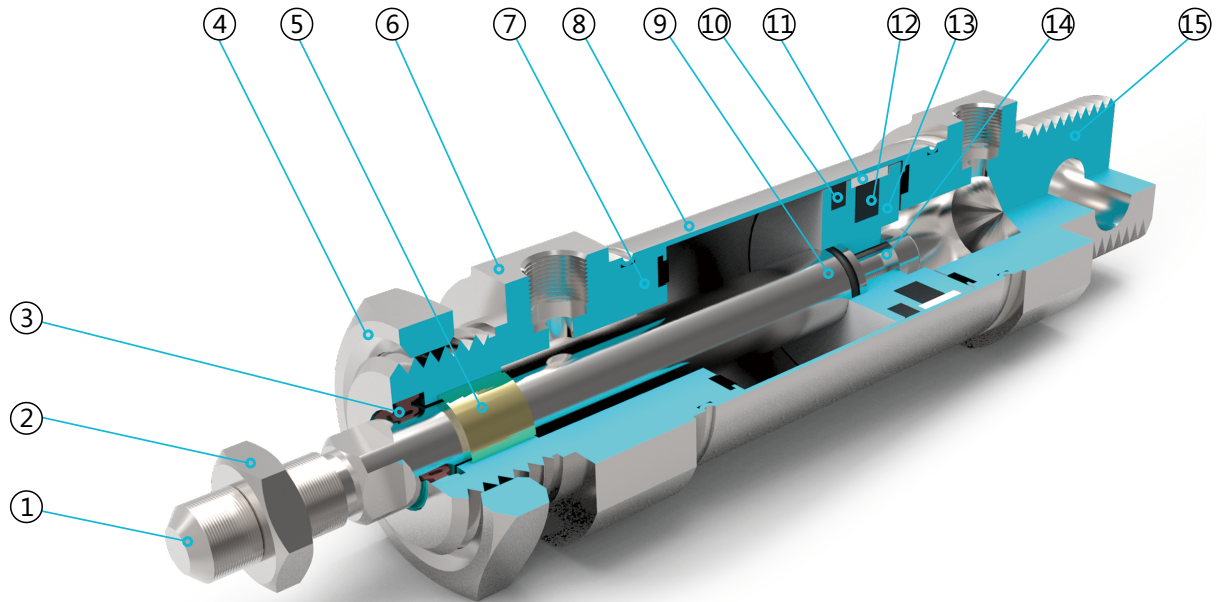

Parts

Number	Name	Number	Name
1	Piston rod	9	O ring
2	Hexagon nut	10	Piston seal
3	Shaft seal	11	Anti-friction seal
4	Hexagon nut	12	Magnet
5	DU bearing	13	Piston
6	Front cover	14	Socket head cap screw
7	Cushion adjusting screw	15	Back cover
8	Cushion		

NEW

5V100
5V200
5V300
5V400
JSY
JEL10
JEL-JN
551
4F210
JELVD

DN

DSN
DN/DSN A
MA
MAC
MA/MAC A
MAL
MALC
MAL/MAC L A
SDA

DN Series

Stainless Steel Mini Cylinder

(ISO6432 Standard)



We make the difference

Overall Dimension

DN

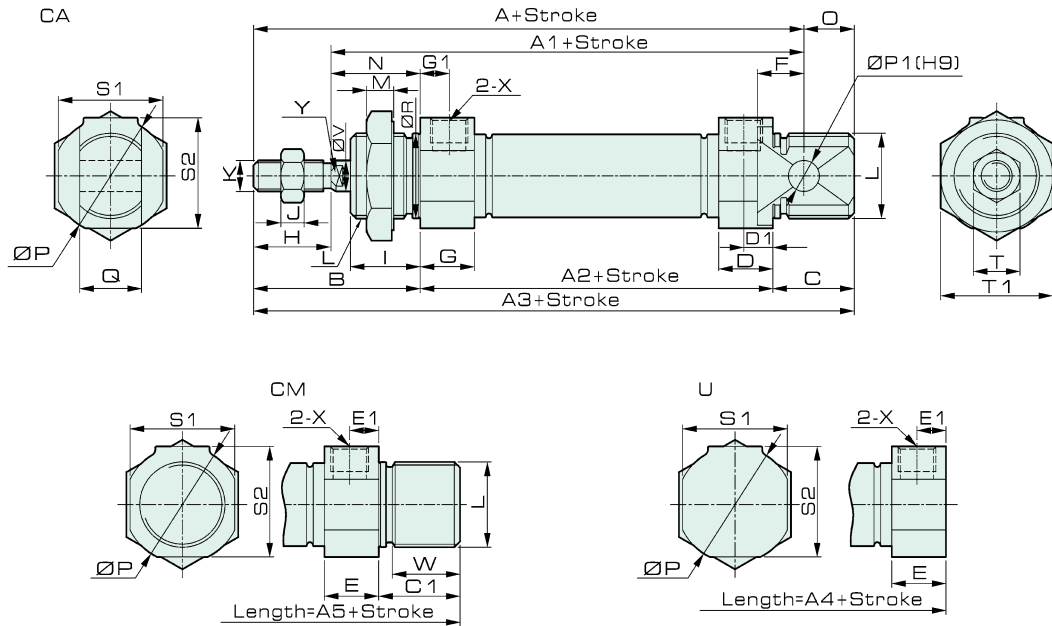

Cylinder with or without magnet is the same size

Dimension

Bore Symbol	A	A1	A2	A3	A4	A5	B	C	C1	D	D1	E	E1	F	G	G1	H	I
8	76	64	46	86	74	86	28	12	12	10	5.5	10	5.5	6	10	5.5	12	12
10	76	64	46	86	74	86	28	12	12	10	5.5	10	5.5	6	10	5.5	12	12
12	91	74	50	105	88	105	38	17	17	10	6	10	6	9	10	6	16	17
16	98	82	55	111	92	111	37	19	19	10.5	6	10.5	6	9	10.5	6	16	16
20	115	95	64	128	107	128	43	21	21	14	7.5	14	7.5	9	14	7.5	20	16
25	126	104	66	137	116	137	50	21	21	15	8	15	8	12	15	8	22	22
32	135	113	72	147	120	132	48	27	12	17	8.5	17	8.5	15	17	8.5	22	18
40	138	115	72	150	123	136	51	27	14	16	8	16	8	15	16	8	23	20

Bore Symbol	J	K	L	M	N	O	P	P1	Q	R	S1	S2	T	T1	X	V	W	Y
8	6	M4×0.7	M12×1.25	6	16	10	17	4	8	12	15	15	7	17	M5×0.8	4	9.3	-
10	6	M4×0.7	M12×1.25	6	16	10	17	4	8	12	15	15	7	17	M5×0.8	4	9.3	-
12	5	M6×1	M16×1.5	6	22	14	21	6	12	16	19	19	10	24	M5×0.8	6	14	5
16	5	M6×1	M16×1.5	6	21	13	21	6	12	16	19	19	10	24	M5×0.8	6	15.5	5
20	6	M8×1.25	M22×1.5	7	23	13	30	8	16	22	27	28.5	12	29	G1/8	8	17.5	6
25	6	M10×1.25	M22×1.5	7	28	11	30	8	16	22	27	28.5	17	29	G1/8	10	17.5	8
32	6	M10×1.25	M27×2	9	26	12	38	10	20	27	35	36.5	17	36	G1/8	12	8	10
40	8	M14×1.5	M33×2	9	28	12	45	10	20	33	42	43.5	22	45	G1/4	16	10	14

Overall Dimension

DS

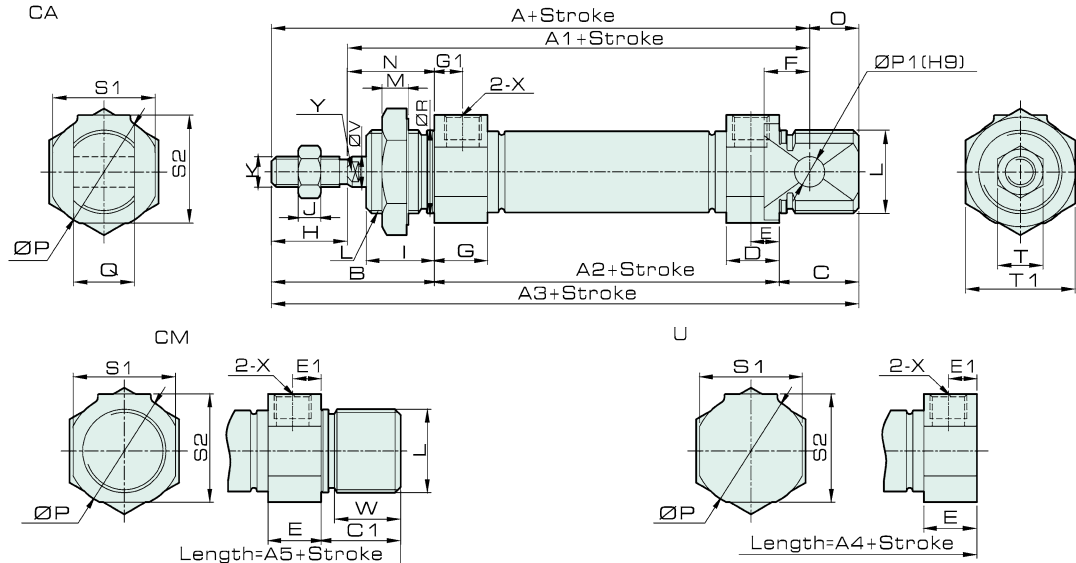

Cylinder with or without magnet is the same size

- NEW
- 5V100
- 5V200
- 5V300
- 5V400
- JSY
- JEL10
- JEL-JN
- 551
- 4F210
- JELVD
- DN**
- DSN
- DN/DSN A.
- MA
- MAC
- MA/MAC A.
- MAL
- MALC
- MAL/MAC L.
- SDA

Dimension

Symbol	A			A1			A2			A3			A4			A5		
Bore/Stroke	0-50	50-100	100-150	0-50	50-100	100-150	0-50	50-100	100-150	0-50	50-100	100-150	0-50	50-100	100-150	0-50	50-100	100-150
8	101	-	-	89	-	-	71	-	-	111	-	-	99	-	-	111	-	-
10	101	-	-	89	-	-	71	-	-	111	-	-	99	-	-	111	-	-
12	116	-	-	99	-	-	75	-	-	130	-	-	113	-	-	130	-	-
16	123	148	-	107	132	-	80	105	-	136	161	-	117	142	-	136	161	-
20	140	165	190	120	145	170	89	114	139	153	178	203	132	157	182	153	178	203
25	151	176	201	129	154	179	91	116	141	162	187	212	141	166	191	162	187	212
32	160	185	210	138	163	188	97	122	147	172	197	222	145	170	195	157	182	207
40	163	188	213	140	165	190	97	122	147	175	200	225	148	173	198	161	186	211

Bore Symbol	B	C	C1	D	D1	E	E1	F	G	G1	H	I	J	K	L
8	28	12	12	10	5.5	10	5.5	6	10	5.5	12	12	6	M4×0.7	M12×1.25
10	28	12	12	10	5.5	10	5.5	6	10	5.5	12	12	6	M4×0.7	M12×1.25
12	38	17	17	10	6	10	6	9	10	6	16	17	5	M6×1	M16×1.5
16	37	19	19	10.5	6	10.5	6	9	10.5	6	16	16	5	M6×1	M16×1.5
20	43	21	21	14	7.5	14	7.5	9	14	7.5	20	16	6	M8×1.25	M22×1.5
25	50	21	21	15	8	15	8	12	15	8	22	22	6	M10×1.25	M22×1.5
32	48	27	12	17	8.5	17	8.5	15	17	8.5	22	18	6	M10×1.25	M27×2
40	51	27	14	16	8	16	8	15	16	8	23	20	8	M14×1.5	M33×2

Bore Symbol	M	N	O	P	P1	Q	R	S1	S2	T	T1	X	V	W	Y
8	6	16	10	17	4	8	12	15	15	7	17	M5×0.8	4	9.3	-
10	6	16	10	17	4	8	12	15	15	7	17	M5×0.8	4	9.3	-
12	6	22	14	21	6	12	16	19	19	10	24	M5×0.8	6	14	5
16	6	21	13	21	6	12	16	19	19	10	24	M5×0.8	6	15.5	5
20	7	23	13	30	8	16	22	27	28.5	12	29	G1/8	8	17.5	6
25	7	28	11	30	8	16	22	27	28.5	17	29	G1/8	10	17.5	8
32	9	26	12	38	10	20	27	35	36.5	17	36	G1/8	12	8	10
40	9	28	12	45	10	20	33	42	43.5	22	45	G1/4	16	10	14

DN Series

Stainless Steel Mini Cylinder

(ISO6432 Standard)



We make the difference

Overall Dimension

DT

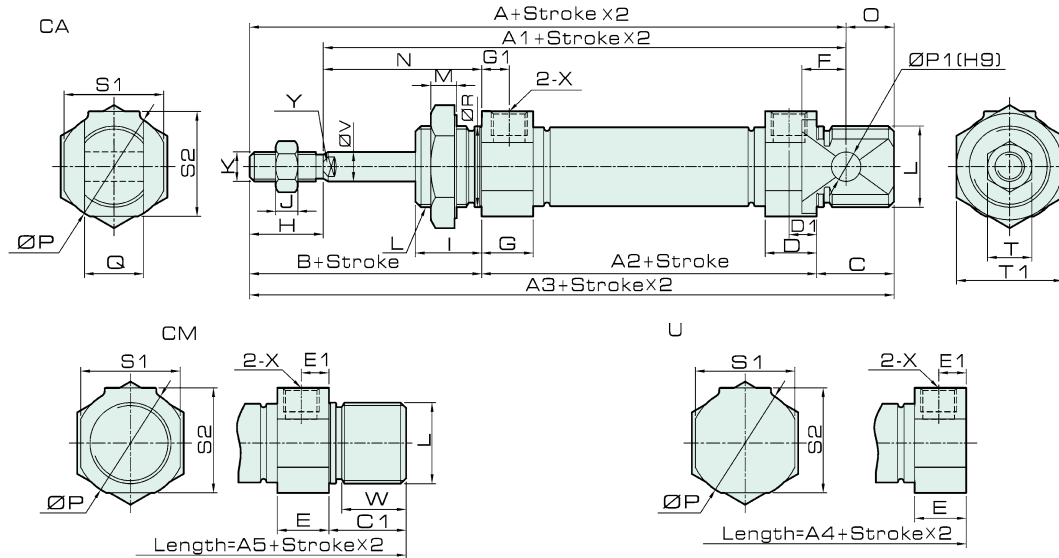

Cylinder with or without magnet is the same size

Dimension

Symbol	A			A1			A2			A3			A4			A5			
	Bore/Stroke	0-50	50-100	100-150	0-50	50-100	100-150	0-50	50-100	100-150	0-50	50-100	100-150	0-50	50-100	100-150	0-50	50-100	100-150
8	101	-	-	89	-	-	71	-	-	111	-	-	99	-	-	111	-	-	-
10	101	-	-	89	-	-	71	-	-	111	-	-	99	-	-	111	-	-	-
12	116	-	-	99	-	-	75	-	-	130	-	-	113	-	-	130	-	-	-
16	123	148	-	107	132	-	80	105	-	136	161	-	117	142	-	136	161	-	-
20	140	165	190	120	145	170	89	114	139	153	178	203	132	157	182	153	178	203	-
25	151	176	201	129	154	179	91	116	141	162	187	212	141	166	191	162	187	212	-
32	160	185	210	138	163	188	97	122	147	172	197	222	145	170	195	157	182	207	-
40	163	188	213	140	165	190	97	122	147	175	200	225	148	173	198	161	186	211	-

Bore Symbol	B	C	C1	D	D1	E	E1	F	G	G1	H	I	J	K	L
8	28	12	12	10	5.5	10	5.5	6	10	5.5	12	12	6	M4×0.7	M12×1.25
10	28	12	12	10	5.5	10	5.5	6	10	5.5	12	12	6	M4×0.7	M12×1.25
12	38	17	17	10	6	10	6	9	10	6	16	17	5	M6×1	M16×1.5
16	37	19	19	10.5	6	10.5	6	9	10.5	6	16	16	5	M6×1	M16×1.5
20	43	21	21	14	7.5	14	7.5	9	14	7.5	20	16	6	M8×1.25	M22×1.5
25	50	21	21	15	8	15	8	12	15	8	22	22	6	M10×1.25	M22×1.5
32	48	27	12	17	8.5	17	8.5	15	17	8.5	22	18	6	M10×1.25	M27×2
40	51	27	14	16	8	16	8	15	16	8	23	20	8	M14×1.5	M33×2

Bore Symbol	M	N	O	P	P1	Q	R	S1	S2	T	T1	X	V	W	Y
8	6	16	10	17	4	8	12	15	15	7	17	M5×0.8	4	9.3	-
10	6	16	10	17	4	8	12	15	15	7	17	M5×0.8	4	9.3	-
12	6	22	14	21	6	12	16	19	19	10	24	M5×0.8	6	14	5
16	6	21	13	21	6	12	16	19	19	10	24	M5×0.8	6	15.5	5
20	7	23	13	30	8	16	22	27	28.5	12	29	G1/8	8	17.5	6
25	7	28	11	30	8	16	22	27	28.5	17	29	G1/8	10	17.5	8
32	9	26	12	38	10	20	27	35	36.5	17	36	G1/8	12	8	10
40	9	28	12	45	10	20	33	42	43.5	22	45	G1/4	16	10	14

Overall Dimension

DND

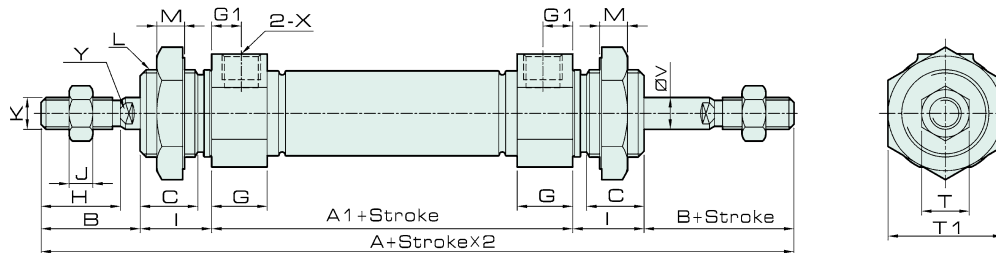

Cylinder with or without magnet is the same size

DNJ

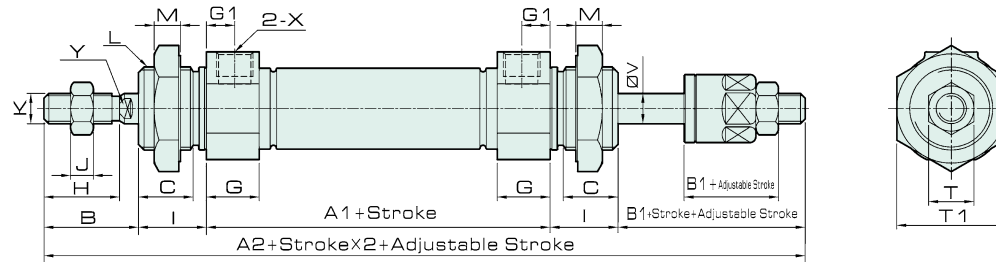

Cylinder with or without magnet is the same size

Dimension

Bore Symbol	A	A1	A2	B	B1	C	D	G	G1	H	I	J	K	L	M	T	T1	V	X
8	102	46	100.5	16	14.5	9.3	-	10	5.5	12	12	6	M4×0.7	M12×1.25	6	7	17	4	M5×0.8
10	102	46	100.5	16	14.5	9.3	-	10	5.5	12	12	6	M4×0.7	M12×1.25	6	7	17	4	M5×0.8
12	126	50	126	21	21	14	5	10	6	16	17	5	M6×1	M16×1.5	6	10	24	6	M5×0.8
16	129	55	129	21	21	13	5	10.5	6	16	16	5	M6×1	M16×1.5	6	10	24	6	M5×0.8
20	150	64	150	27	25	14.5	6	14	7.5	20	16	6	M8×1.25	M22×1.5	7	12	29	8	G1/8
25	166	66	165	28	27	18.5	8	15	8	22	22	6	M10×1.25	M22×1.5	7	17	29	10	G1/8
32	168	72	165	30	27	14	10	17	8.5	22	18	6	M10×1.25	M27×2	9	17	36	12	G1/8
40	174	72	172	31	29	16	14	16	8	23	20	8	M14×1.5	M33×2	9	22	45	16	G1/4

- NEW
- 5V100
- 5V200
- 5V300
- 5V400
- JSY
- JEL10
- JEL-JN
- 551
- 4F210
- JELVD
- DN
- DSN
- DN/DSN A.
- MA
- MAC
- MA/MAC A.
- MAL
- MALC
- MAL/MALC A.
- SDA