

# Preparation unit—Regulator



## GR Series



GR

### Symbol

No Reverse Flow valve is attached      Reverse Flow valve is attached



### Product feature

1. Embedded square pressure gauge is used to save installation space. (External circular pressure gauge is also optional).
2. The pressed-in self-locking mechanism can prevent the abnormal movement of the set pressure caused by external interfere.
3. Balanced design is adopted for the pressure adjustment mechanism.
4. In addition to panel installation, the bracket is optional for installation.
5. In addition to standard type, lower pressure type is optional (the highest adjustable pressure is 0.4MPa).

### Specification

Model	GR200-06	GR200-08	GR300-08	GR300-10	GR300-15	GR400-10	GR400-15	GR600-20	GR600-25
Fluid	Air								
Port size	1/8"	1/4"	1/4"	3/8"	1/2"	3/8"	1/2"	3/4"	1"
Pressure range	0.05~0.9MPa(7~130psi)								
Max. pressure	1.0MPa(145psi)								
Proof pressure	1.5MPa(215psi)								
Temperature range	-20~70°C								
Weight	160g		350g			720g		1700g	

### Ordering code

GR200 08 L   F 1  K

**Model**  
 GR200: G200 Series Regulator  
 GR300: G300 Series Regulator  
 GR400: G400 Series Regulator  
 GR600: G600 Series Regulator

Model	Port size
GR200	06: 1/8"
	08: 1/4"
GR300	08: 1/4"
	10: 3/8"
GR400	10: 3/8"
	15: 1/2"
GR600	20: 3/4"
	25: 1"

**Type code**  
 Blank: Standard  
 L: Lower pressure ①

**Code of reflux valve**  
 Blank: No Reverse flow valve is attached  
 K: Reverse flow valve is attached

**Thread type**  
 Blank: PT  
 T: NPT  
 G: G

**Scale**  
 1: MPa  
 2: psi  
 3: bar

**Pressure gauge shape**  
 F: Square  
 C: Circular

**Pressure gauge**  
 Blank: Pressure gauge  
 N: No pressure gauge

**Accessories**  
 Blank: Bracket  
 J: No bracket(standard configuration)

① The maximum work pressure of lower pressure type is 0.4MPa(58psi). ② Please refer to page 144 for details of reflux valve.

### Inner structure and Material of major parts

GR200

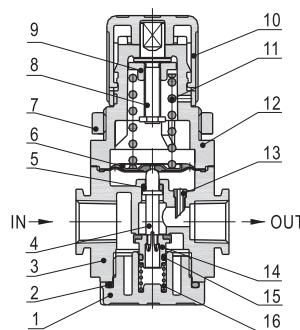

GR600

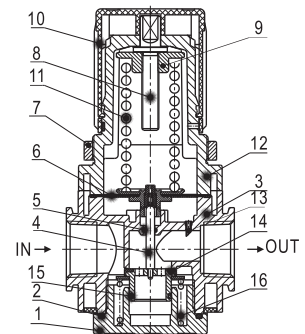

No.	Item	Material	No.	Item	Material
1	Valve cap	Aluminum alloy	9	Regulator nut	Steel
2	O-ring	NBR	10	Pressure knob	POM
3	Body	Aluminum alloy	11	Pressure spring	SWC
4	Spool	Brass(GR600)\POM(others)	12	Adjusting seat	Aluminum alloy(GR600)\POM(others)
5	O-ring	NBR	13	Feed back tube	POM
6	Diaphragm	SUS304 & Rubber	14	Pressure plug	Brass & steel
7	Fixed ring	Aluminum alloy(GR600)\POM(others)	15	O-ring	NBR
8	Adjusting spindle	Steel	16	Spring	Stainless steel

# Preparation unit—Regulator

## GR Series

### Pressure and feature of flow

**Pressure chart** Applicable type: GR200

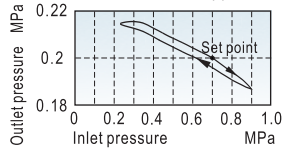

Applicable type: GR300

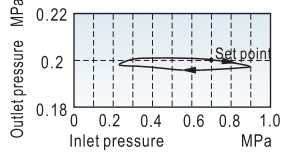

Applicable type: GR400

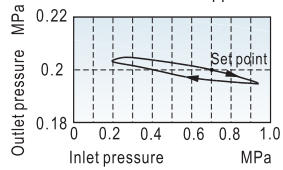

Applicable type: GR600

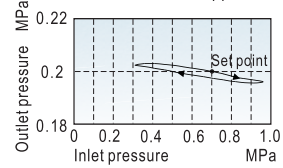

**Flow chart** Applicable type: GR200  
Inlet pressure: 0.7MPa

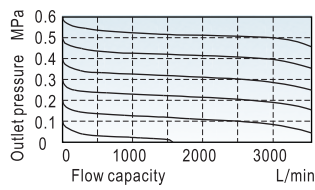

Applicable type: GR300  
Inlet pressure: 0.7MPa

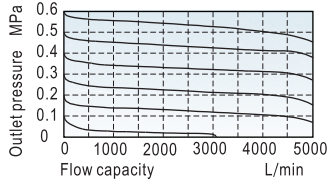

Applicable type: GR400  
Inlet pressure: 0.7MPa

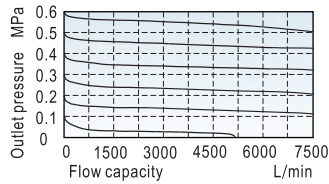

Applicable type: GR600  
Inlet pressure: 0.7MPa

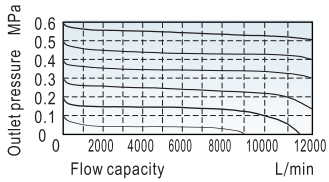

### Dimensions

**GR200**

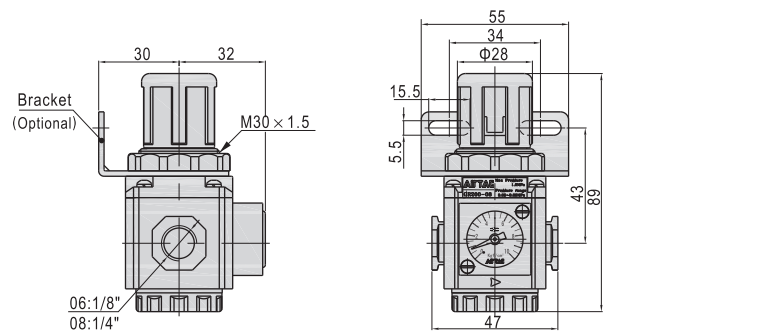

**GR300, GR400**

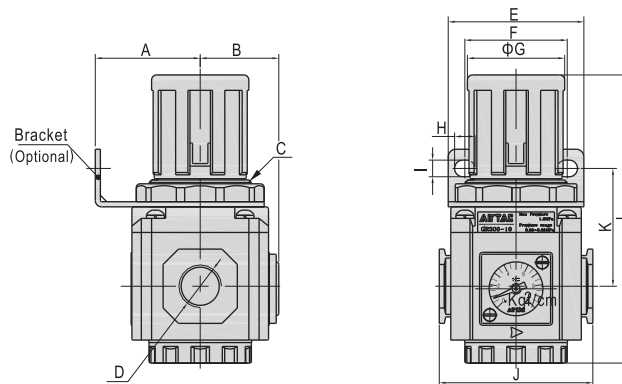

Model/Item	A	B	C	D	E	F	G	H	I	J	K	L
GR300-08	41	31	M40x1.5	1/4"	53	40	38	8	6.5	60	46	112.5
GR300-10	41	31	M40x1.5	3/8"	53	40	38	8	6.5	60	46	112.5
GR300-15	41	31	M40x1.5	1/2"	53	40	38	8	6.5	60	46	112.5
GR400-10	50	40	M55x2.0	3/8"	72	55	52	11	8.5	80	53	140.5
GR400-15	50	40	M55x2.0	1/2"	72	55	52	11	8.5	80	53	140.5

**GR600**

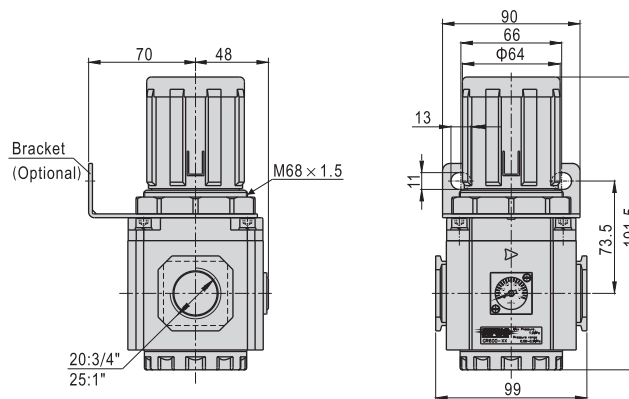

GR