





# Standard cylinder——SE Series

In accordance with ISO15552 and VDMA24562 standard

## Product series

Series name	Mounting type									Acting type	Bore size	Collocation of sensor switch	
	Basic	LB	FA	FB	CA	CB	CR	TC	FTC			CS1-E	DS1-E
Double acting type: SE 	●	●	●	●	●	●	●	●	●	Double acting	32 40 50 63 80 100 125	●	●
Double rod type: SED 	●	●	●				●	●				●	●
Adjustable stroke type: SEJ 	●	●	●				●	●				●	●
	●	●	●				●	●				●	●
	●	●	●				●	●				●	●
	●	●	●				●	●				●	●
Page	170			172						419			



SE

## Installation and application

- When load changes in the work, the cylinder with abundant output capacity shall be selected.
- Relative cylinder with high temperature resistance or corrosion resistance shall be chosen under the condition of high temperature or corrosion.
- Necessary protection measure shall be taken in the environment with higher humidity, much dust or water drops, oil dust and welding dregs.
- Dirty substances in the pipe must be eliminated before cylinder is connected with pipeline to prevent the entrance of particles into the cylinder.
- The medium used by cylinder shall be filtered to 40 μm or below.
- Anti-freezing measure shall be adopted under low temperature environment to prevent moisture freezing.
- The cylinder shall be carried out test run without load before application. Prior to run, buffer shall be turned to the minimum and gradually released to avoid the damage on cylinder caused by excessive impact.
- The cylinder shall avoid the influence of side load in operation to maintain the normal work of cylinder and extend the service life.
- If the cylinder is dismantled and stored for a long time, please conduct anti-rust treatment to the surface. Anti-dust caps shall be added in air inlet and outlet ports.

## Criteria for selection: Cylinder thrust

Unit: Newton(N)

Bore size (mm)	Rod size (mm)	Acting type	Pressure area (mm <sup>2</sup> )	Operating pressure (MPa)								
				0.1	0.2	0.3	0.4	0.5	0.6	0.7	0.8	0.9
32	12	Double acting Push side	804	80.4	160.8	241.2	321.6	402.0	482.4	562.8	643.2	723.6
		Double acting Pull side	690	69.0	138.0	207.0	276.0	345.0	414.0	483.0	552.0	621.0
40	16	Double acting Push side	1256	125.6	251.2	376.8	502.4	628.0	753.6	879.2	1002.4	1130.4
		Double acting Pull side	1055	105.5	211.0	316.5	422.0	527.5	633.0	738.5	844.0	949.5
50	20	Double acting Push side	1963	196.3	392.6	588.9	785.2	981.5	1177.8	1374.1	1570.4	1766.7
		Double acting Pull side	1649	164.9	329.8	494.7	659.6	824.5	989.4	1154.3	1399.2	1484.1
63	20	Double acting Push side	3117	311.7	623.4	935.1	1246.8	1558.5	1870.2	2181.9	2493.6	2805.3
		Double acting Pull side	2803	280.3	560.6	840.9	1121.2	1401.5	1681.8	1962.1	2242.4	2522.7
80	25	Double acting Push side	5026	502.6	1005.2	1507.8	2010.4	2513.0	3015.6	3518.2	4020.8	4523.4
		Double acting Pull side	4536	453.6	907.2	1360.8	1814.4	2268.0	2721.6	3175.2	3628.8	4082.4
100	25	Double acting Push side	7853	785.3	1570.6	2355.9	3141.2	3926.5	4711.8	5497.1	6282.4	7067.7
		Double acting Pull side	7362	736.2	1472.4	2208.6	2948.6	3681.0	4417.2	5153.4	5889.6	6625.8
125	32	Double acting Push side	12272	1227.2	2454.4	3681.6	4908.8	6136.0	7363.2	8590.4	9817.6	11044.8
		Double acting Pull side	11468	1146.8	2293.6	3440.4	4587.2	5734.0	6880.8	8027.6	9174.4	10321.2



# ISO15552 Standard cylinder

## SE Series

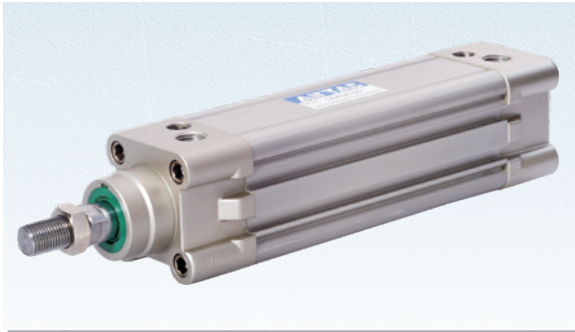

### Symbol

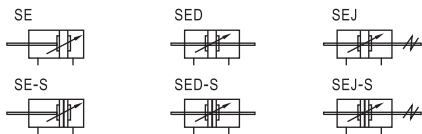

### Product feature

1. ISO15552 and VDMA24562 standard cylinder;
2. The piston seal is composed of two Y-shape one-way seal structure, which has compensation function, long service life and low start-up pressure;
3. The square aluminum pipe without tie rod has good corrosion resistance;
4. The buffer adjustment of cylinder is smooth and steady;
5. Cylinders and accessories for installation with several specifications are optional.

### Specification

Bore size(mm)	32	40	50	63	80	100	125					
Acting type	Double acting											
Fluid	Air(to be filtered by 40 μm filter element)											
Mounting type	SE	Basic	FA	FB	CA	CB	CR	LB	TC	FTC	TCM1	TCM2
type	SED, SEJ	Basic	FA	LB	TC	FTC	TCM1	TCM2				
Operating pressure	0.1~1.0MPa(15~145psi)(1.0~10.0bar)											
Proof pressure	1.5MPa(215psi)(15bar)											
Temperature °C	-20~80											
Speed range mm/s	30~800							30~500				
Stroke tolerance	0~250 <sup>+1.0</sup> <sub>0</sub>							251~1000 <sup>+1.4</sup> <sub>0</sub>	1001~1500 <sup>+1.8</sup> <sub>0</sub>			
Cushion type	Variable cushion											
Adjustable cushion stroke mm	27			30			36		40			
Port size ①	1/8"		1/4"		3/8"		1/2"					

① PT thread, NPT thread and G thread are available.  
Add) Refer to P419~442 for detail of sensor switch.

### Stroke

Bore size (mm)	Standard stroke (mm)											Max. std stroke	Max. stroke										
32	25	50	75	80	100	125	150	160	175	200	250	300	350	400	450	500	1000	1800					
40	25	50	75	80	100	125	150	160	175	200	250	300	350	400	450	500	600	700	800	1200	1800		
50	25	50	75	80	100	125	150	160	175	200	250	300	350	400	450	500	600	700	800	900	1000	1200	1800
63	25	50	75	80	100	125	150	160	175	200	250	300	350	400	450	500	600	700	800	900	1000	1500	1800
80	25	50	75	80	100	125	150	160	175	200	250	300	350	400	450	500	600	700	800	900	1000	1500	1800
100	25	50	75	80	100	125	150	160	175	200	250	300	350	400	450	500	600	700	800	900	1000	1500	1800
125	25	50	75	80	100	125	150	160	175	200	250	300	350	400	450	500	600	700	800	900	1000	1500	1800

Note) Consult us for non-standard stroke.

### Ordering code

SE 80 □ × 50 S □ □ □

SED 80 □ × 50 S □ □ □

SEJ 80 □ × 50-20 S □ □ □

**Model**

- SE: Double acting type
- SED: Double rod type
- SEJ: Adjustable stroke type

**Bore size**

32 40 50 63 80 100 125

**Rod Material**

- Blank: Medium carbon steel
- A: SUS420J2
- B: SUS304
- C: SUS316

**Stroke**

Refer to stroke table for details

**Adjustable stroke**

- 10: 10mm
- 20: 20mm
- 30: 30mm
- 40: 40mm
- 50: 50mm
- 75: 75mm
- 100: 100mm

**Magnet**

- Blank: Without magnet
- S: With magnet

**Thread type**

- Blank: PT
- T: NPT
- G: G

**Seals Material**

- Blank: TPU
- H: Viton
- N: NBR

**Mounting type** ①

Mounting type	Available series	Memo
Blank		
LB	SE SED SEJ	
FA		
FB		
CA	SE	
CB		Be used with CB
CR		
FTC	SE SED SEJ	Be used with TCM1 TCM2
TC		

① Please refer to page 172~174 for accessory parts.



# ISO15552 Standard cylinder

## SE Series

### Inner structure and material of major parts

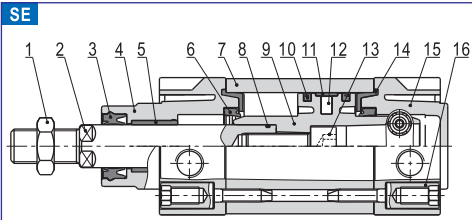

NO.	Item	Material
1	Rod nut	Carbon steel\Stainless steel
2	Piston rod	Carbon steel with 20 μ m chrome plated or Stainless steel
3	Front cover packing	TPU
4	Front cover	Aluminum alloy
5	Bushing	Wear resistant material
6	Cushing O-ring	TPU
7	Barrel	Aluminum alloy
8	O-ring	NBR
9	Piston	Aluminum alloy
10	Piston Seal	TPU
11	Wear ring	Wear resistant material
12	Magnet	Plastic\Rubber(Φ 125)
13	Bolt	Carbon steel
14	Buffer gasket	TPU
15	Back cover	Aluminum alloy
16	Screw	Carbon steel\Stainless steel

### Dimensions

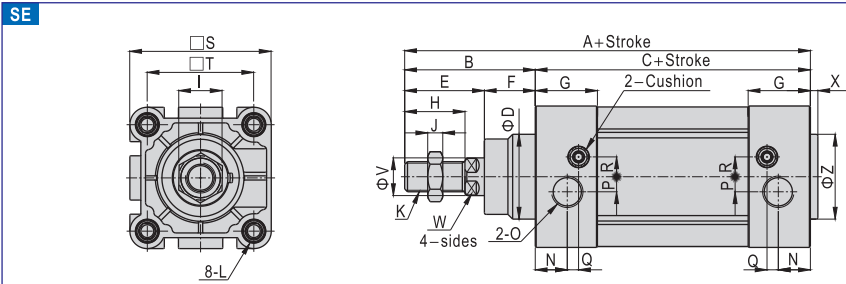

Bore size\Item	A	B	C	D	E	F	G	H	I	J	K
32	142	48	94	30	29	19	27.5	22	17	6	M10×1.25
40	159	54	105	35	33	21	32	24	17	7	M12×1.25
50	175	69	106	40	42	27	31	32	23	8	M16×1.5
63	190	69	121	45	42	27	33	32	23	8	M16×1.5
80	214	86	128	45	53	33	33	40	26	10	M20×1.5
100	229	91	138	55	55	36	37	40	26	10	M20×1.5
125	279	119	160	60	74	45	46	54	41	13.5	M27×2

Bore size\Item	L	N	O	P	Q	R	S	T	V	W	X	Z
32	M6	13.5	1/8"	5.8	6	6.3	46.5	32.5	12	10	3	30
40	M6	17.5	1/4"	6	5.5	9	54	38	16	13	3.5	35
50	M8	14	1/4"	8	5	10.5	64	46.5	20	17	3.5	40
63	M8	17	3/8"	8	6	10.5	75	56.5	20	17	4	45
80	M10	16.5	3/8"	8	8.5	12.5	93	72	25	22	4	45
100	M10	19.5	1/2"	10	7	12	110	89	25	22	4	55
125	M12	23	1/2"	11	12	11	134	110	32	27	4	60

Remark: The dimensions of magnet type cylinder are the same as non-magnet type cylinder.

### SED

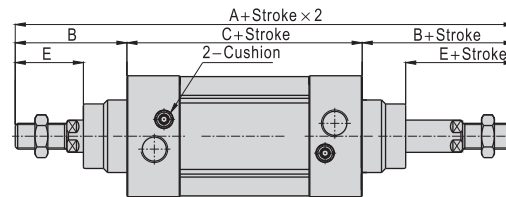

### SEJ

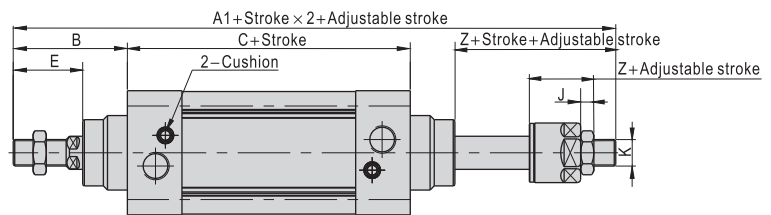

Bore size\Item	A	A1	B	C	E	Z	J	K
32	190	188	48	94	29	27	6	M10X1.25
40	213	208	54	105	33	28	7	M12X1.25
50	244	231	69	106	42	29	8	M16X1.5
63	259	246	69	121	42	29	8	M16X1.5
80	300	282.5	86	128	53	35.5	10	M20X1.5
100	320	300.5	91	138	55	35.5	10	M20X1.5
125	398	366.5	119	160	74	42.5	13.5	M27X2.0

Remark:  
 1. The dimensions of magnet type cylinder are the same as non-magnet type cylinder.  
 2. The unmarked dimension is the same as SE standard type.



SE

# ISO1552 Standard cylinder



## Accessories

### Ordering code

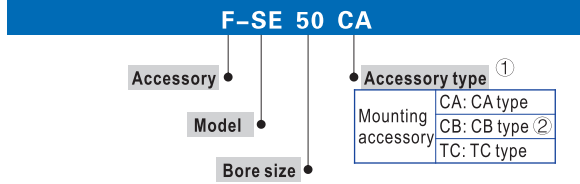

- ① The listed accessories are for SE cylinder. Accessories that are adaptable to other cylinders are not shown. Please refer to accessory list on P174 for selection and ordering information.  
 ② CB is attached with relevant PIN.



SE

### Accessory selection

Accessories	SE		SED		SEJ	
	Standard	With magnet	Standard	With magnet	Standard	With magnet
Mounting accessory						
LB	●	●	●	●	●	●
FA	●	●	●	●	●	●
FB	●	●	×	×	×	×
CA	●	●	×	×	×	×
CB	●	●	×	×	×	×
CR	●	●	×	×	×	×
TC	●	●	●	●	●	●
FTC	●	●	●	●	●	●
TCM1	●	●	●	●	●	●
TCM2	●	●	●	●	●	●
Knuckle						
I	●	●	●	●	●	●
Y	●	●	●	●	●	●
U	●	●	●	●	●	●
F	●	●	●	●	●	●
Sensor switch						
CS1-E	×	●	×	●	×	●
CS1-EX	×	●	×	●	×	●
DS1-E	×	●	×	●	×	●
DS1-EN	×	●	×	●	×	●
DS1-EP	×	●	×	●	×	●

- ① Please refer to P415~418 for knuckle detail.  
 ② Please refer to P419~442 for detail of sensor switch.

### Material of accessories

Accessories	Mounting accessories										Knuckle		
	LB	FA	FB	CA	CB	CR	FTC	TCM1	TCM2	I	Y	F	U
Bore size													
32~100	○	●	●	◇	◇	◇	■	■	■	□	□	□	□
125	■	■	■	■	■	■	■	■	■	□	□	□	□

- Aluminum alloy, ▲—S45C, ■—Cast steel,  
 ○—Low carbon steel, ◇—Nodular cast iron, □—Carbon steel.

### Dimensions

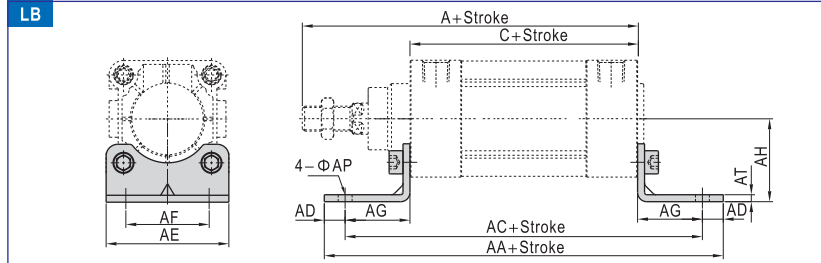

Bore size\Item	A	C	AA	AC	AD	AE	AF	AG	AH	AP	AT
32	142	94	158	142	8	47	32	24	32	7	3
40	159	105	179	161	9	53	36	28	36	9	3
50	175	106	190	170	10	65	45	32	45	9	3
63	190	121	209	185	12	75	50	32	50	9	3
80	214	128	248	210	19	95	63	41	63	12.5	4
100	229	138	266	228	19	115	75	45	71	14.5	4
125	279	160	290	250	20	140	90	45	90	16.5	8

### FA/FB

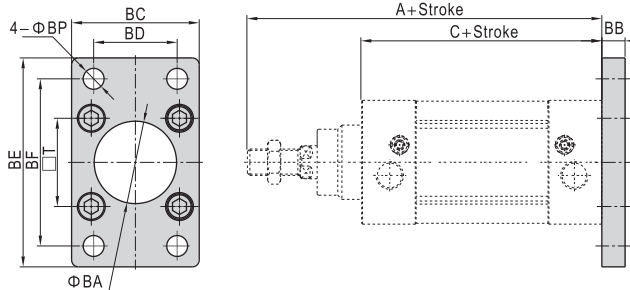
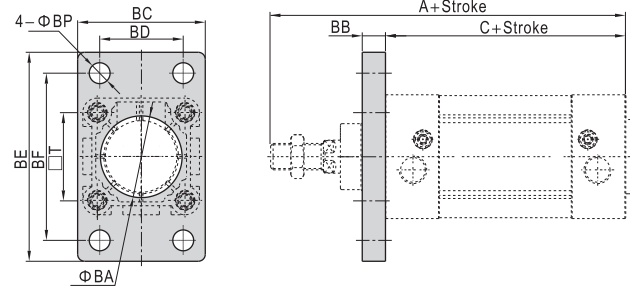

Bore size\Item	A	C	BA	BB	BC	BD	BE	BF	BP	T
32	142	94	30.5	10	47	32	80	64	7	32.5
40	159	105	35.5	10	53	36	90	72	9	38
50	175	106	40.5	12	65	45	108	90	9	46.5
63	190	121	45.5	12	75	50	118	100	9	56.5
80	214	128	45.5	16	95	63	150	126	12.5	72
100	229	138	55.5	16	115	75	176	150	14.5	89
125	279	160	60.5	20	139	90	218	180	16.5	110

### CA

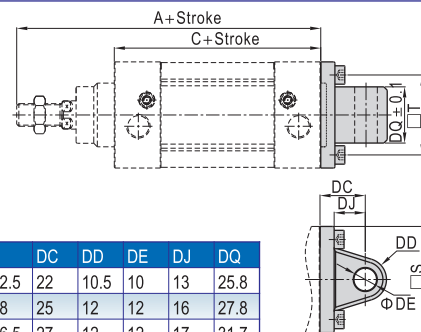

Bore size\Item	A	C	S	T	DC	DD	DE	DJ	DQ
32	142	94	46.5	32.5	22	10.5	10	13	25.8
40	159	105	54	38	25	12	12	16	27.8
50	175	106	64	46.5	27	12	12	17	31.7
63	190	121	75	56.5	32	15	16	22	39.7
80	214	128	93	72	36	15.5	16	22	49.7
100	229	138	110	89	41	20	20	27	59.7
125	279	160	134	110	50	24	25	33	69.7



# ISO1552 Standard cylinder

## Accessories

### CB

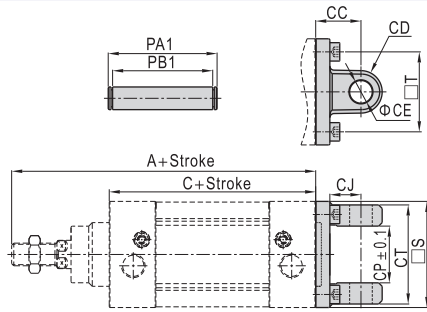

Bore size\Item	A	C	CC	CD	CE	CJ	CP	CT	PA1	PB1	S	T
32	142	94	22	10.5	10	13	26	45	51	45.5	46.5	32.5
40	159	105	25	12	16	28	52	59	52.5	54	38	
50	175	106	27	12	12	17	32	60	67	60.5	64	46.5
63	190	121	32	15	16	22	40	70	77	70.5	75	56.5
80	214	128	36	15.5	16	22	50	90	97	90.5	93	72
100	229	138	41	20	20	27	60	110	119	110.5	110	89
125	279	160	50	24	25	33	70	130	139	130.5	134	110

### CR

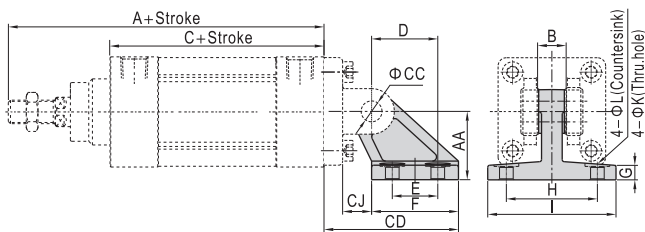

Bore size\Item	A	AA	B	C	CC	CD	CJ	D	E	F	G	H	I	K	L
32	142	32	26	94	10	50	10	21	18	31	8	38	51	6.6	-
40	159	36	28	105	12	56	12	24	22	35	10	41	54	6.6	-
50	175	45	32	106	12	68	13	33	30	45	12	50	65	9	-
63	190	50	40	121	16	77	17	37	35	50	12	52	67	9	-
80	214	63	50	128	16	93	19	47	40	60	14	66	86	11	18
100	229	71	60	138	20	106	22	55	50	70	15	76	96	11	18
125	279	90	70	160	25	135	26	70	60	90	20	94	124	14	20

Note) CR can't be used alone, it must be used with CB.

### FTC

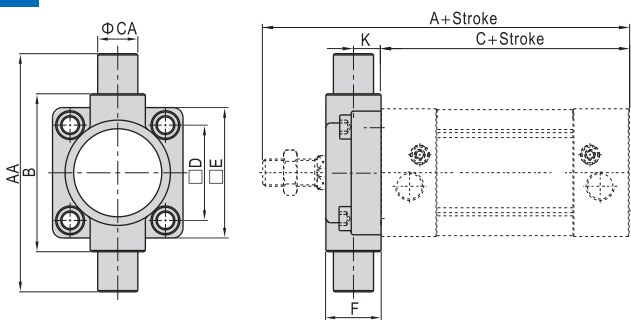

Bore size\Item	A	C	AA	B	CA	D	E	F	K
32	142	94	74	50	12	32.5	46	19	10
40	159	105	95	63	16	38	52	21	10
50	175	106	107	75	16	46.5	64	26	12
63	190	121	130	90	20	56.5	74	28	12
80	214	128	150	110	20	72	94	31	16
100	229	138	182	132	25	89	114	35	16
125	279	160	210	160	25	110	139	43	20

### TCM1

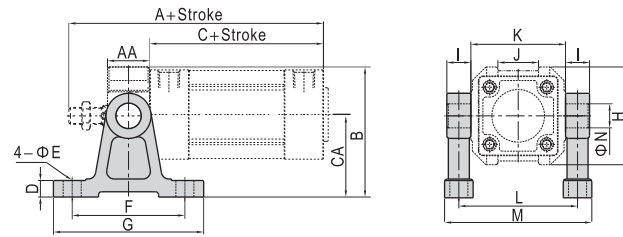

Bore size\Item	A	C	AA	B	CA	D	E	F	G	H	I	J	K	L	M	N
32	142	94	19	66	40	11	9	60	80	52	12	20	50	62	77	12
40	159	105	21	86.5	54	11	12	75	100	65	16	27	63	79	98	16
50	175	106	26	91.5	54	11	12	75	100	75	16	31	75	91	110	16
63	190	121	28	115	70	11	12	85	110	90	20	42	90	110	133	20
80	214	128	31	126	70	11	12	85	110	112	20	54	110	130	153	20
100	229	138	35	157.5	90	19	18	115	155	135	25	68	135	157	185	25
125	279	160	43	169.3	90	19	18	115	155	170	25	80	160	185	213	25

Note) The installation position of the accessories can not be adjusted arbitrarily.

### TCM2

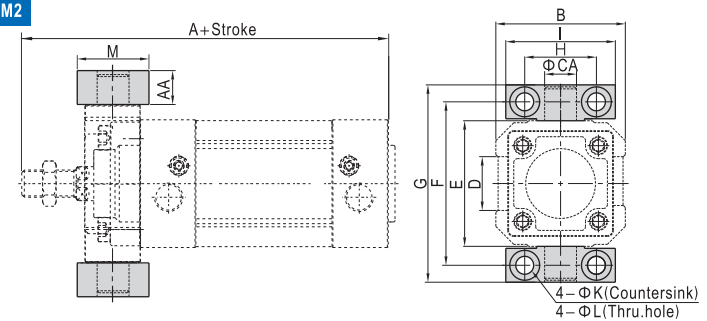

Bore size\Item	A	AA	B	CA	D	E	F	G	H	I	K	L	M
32	142	14	52	12	20	50	66	80	32	46	11	7	30
40	159	17	65	16	27	63	82	99	36	55	15	9	36
50	175	17	75	16	31	75	94	111	36	55	15	9	36
63	190	20.5	90	20	42	90	113.5	134	42	65	18	11	40
80	214	20.5	112	20	54	110	133.5	154	42	65	18	11	40
100	229	24.5	135	25	68	132	159.5	184	50	75	20	14	50
125	279	24.5	170	25	80	160	187.5	212	50	75	20	14	50

Note) The installation position of the accessories can not be adjusted arbitrarily.



SE

# ISO15552 Standard cylinder

## Accessories

### List for ordering code of accessories



SE

Accessories Bore size	Mounting accessory			
	LB	FA	FB	CA
32	F-SI32LB	F-SI32FA	F-SI32FB	F-SE32CA
40	F-SI40LB	F-SI40FA	F-SI40FB	F-SE40CA
50	F-SI50LB	F-SI50FA	F-SI50FB	F-SE50CA
63	F-SI63LB	F-SI63FA	F-SI63FB	F-SE63CA
80	F-SI80LB	F-SI80FA	F-SI80FB	F-SE80CA
100	F-SI100LB	F-SI100FA	F-SI100FB	F-SE100CA
125	F-SI125LB	F-SI125FA	F-SI125FB	F-SE125CA

Accessories Bore size	Mounting accessory		
	CB	CR	TC ①
32	F-SE32CB	F-SI32CR	F-SE32TC
40	F-SE40CB	F-SI40CR	F-SE40TC
50	F-SE50CB	F-SI50CR	F-SE50TC
63	F-SE63CB	F-SI63CR	F-SE63TC
80	F-SE80CB	F-SI80CR	F-SE80TC
100	F-SE100CB	F-SI100CR	F-SE100TC
125	F-SE125CB	F-SI125CR	F-SE125TC

Accessories Bore size	Mounting accessory		
	FTC	TCM1	TCM2
32	F-SI32FTC	F-SI32TCM1	F-SI32TCM2
40	F-SI40FTC	F-SI40TCM1	F-SI40TCM2
50	F-SI50FTC	F-SI40TCM1	F-SI40TCM2
63	F-SI63FTC	F-SI63TCM1	F-SI63TCM2
80	F-SI80FTC	F-SI63TCM1	F-SI63TCM2
100	F-SI100FTC	F-SI125TCM1	F-SI125TCM2
125	F-SI125FTC	F-SI125TCM1	F-SI125TCM2

Accessories Bore size	Knuckle			
	I: I Knuckle	Y: Y Knuckle	F: F Knuckle	U: U Knuckle
32	F-M10X125I	F-M10X125Y	F-M10X125F	F-M10X125U
40	F-M12X125I	F-M12X125Y	F-M12X125F	F-M12X125U
50	F-M16X150I	F-M16X150Y	F-M16X150F	F-M16X150U
63	F-M16X150I	F-M16X150Y	F-M16X150F	F-M16X150U
80	F-M20X150I	F-M20X150Y	F-M20X150F	F-M20X150U
100	F-M20X150I	F-M20X150Y	F-M20X150F	F-M20X150U
125	F-M27X200I	F-M27X200Y	-	F-M27X200U

Accessories Bore size	Sensor switch				
	CS1-E	CS1-EX	DS1-E	DS1-EN	DS1-EP
32~125	CS1-E	CS1-EX	DS1-E	DS1-EN	DS1-EP

①: TC accessories are under development.

